



Costruito da 1 a 5 sezioni
Manufactured in 1 to 5 sections

Portata nominale
Nominal flow rate.....120 l/min

Pressione MAX di esercizio
MAX working pressure.....220 bar

Contropressione MAX allo scarico
MAX return backpressure.....50 bar

Valvola di MAX PRESSIONE standard tarabile
Standard PRESSURE RELIEF valve, may be set da 10 a 220 bar

Valvola di ritegno unidirezionale ogni sezione / Single-acting check valve for each section
Ricoprimento negativo del cursore / Negative spool overlapping

Cursore reversibile per entrata destra o sinistra
Reversing spool for right-hand or left-hand inlet

Predisposto per la continuazione della linea di pressione (CARRY-OVER) / Preset for CARRY-OVER

Temperatura di esercizio
Working temperature..... min.-25°C ÷ max. 80°C

Trafil. MAX cursore a 100 bar (Temp. 50°C Visc. 27 CST)
MAX spool leakage at 100 bar (Temp. 50°C Visc. 27 CST)..... 21 ml/min

Versione standard: entrata SINISTRA
Standard version: LEFT-HAND inlet

Trattamento antiruggine DACROMET - a richiesta
Rust-preventive treatment DACROMET - on request

MODELLO/MODEL	L (MM)	F (MM)	PESO/WEIGHT (KG)
AMI 701 (a 1 sezione / 1 section)	153	128	11,900
AMI 702 (a 2 sezioni / 2 sections)	198	173	16,400
AMI 703 (a 3 sezioni / 3 sections)	243	218	20,900
AMI 704 (a 4 sezioni / 4 sections)	288	263	25,400
AMI 705 (a 5 sezioni / 5 sections)	333	308	29,900

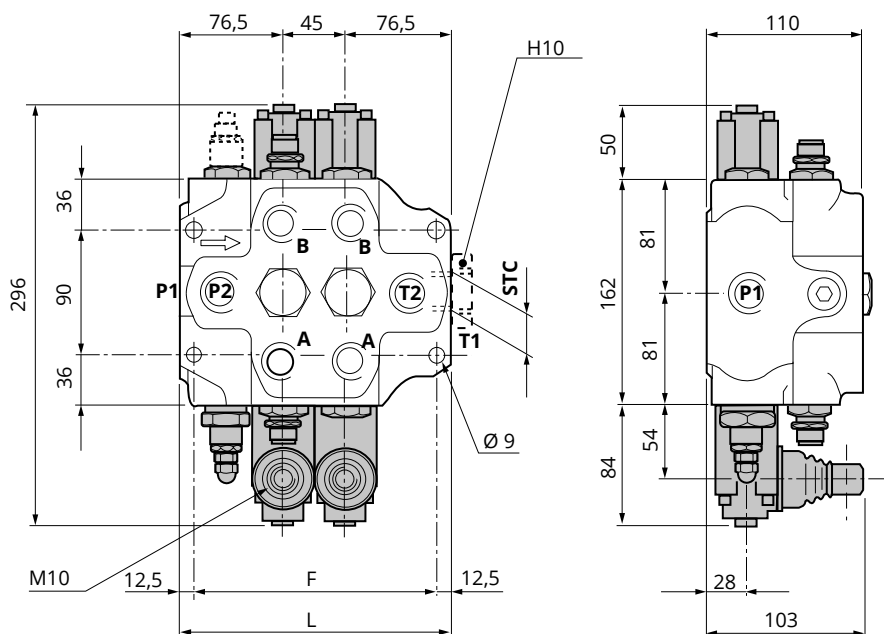

FILETTATURE DISPONIBILI / AVAILABLE THREADS

	STANDARD	A RICHIESTA / ON DEMAND
P1 - P2	3/4" BSP	1" BSP
A - B	3/4" BSP	1" BSP
T2	1" BSP	1" BSP
T1 - STC	1" BSP	1" BSP

VERSIONE MANUALE

MANUAL VERSION

Caduta di pressione entrata - uscita
Pressure drop inlet - outlet

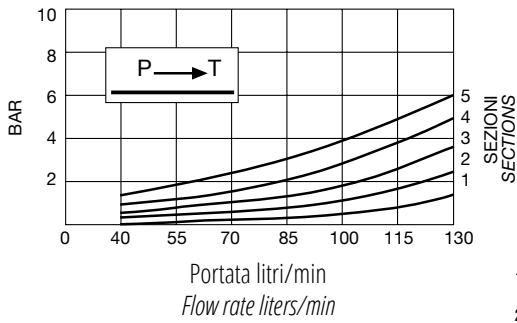

Caduta di pressione utilizzi - uscita
Pressure drop service ports - outlet

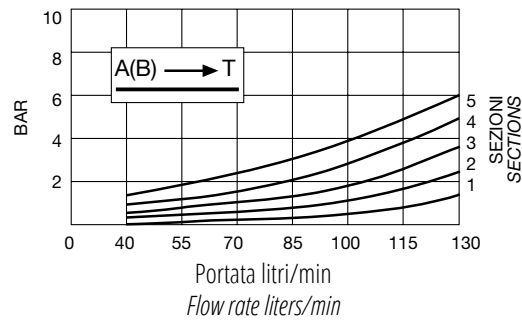

Caduta di pressione entrata - utilizzi
Pressure drop inlet - service ports

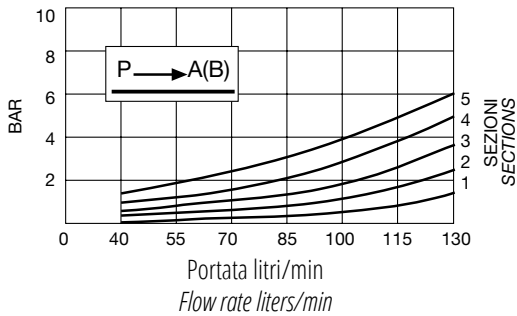

Cursore in serie in pos. comando: flusso da A-B di una sez. ad A-B della sez. serie
Spool in series in control pos. flow from A-B of one sec. to A-B of the series sec

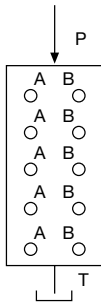
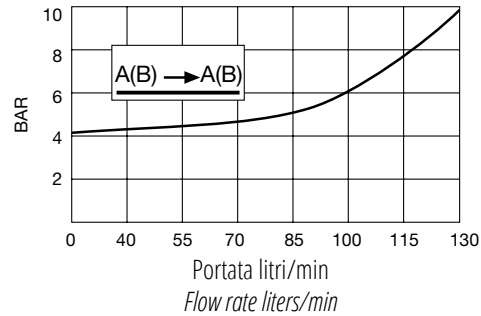

Prove effettuate con olio viscosità 4° e a 50° C
Tests performed with 4° e visc. Oil at 50° C

SCHEMA IDRAULICO

HYDRAULIC SYSTEM DIAGRAM

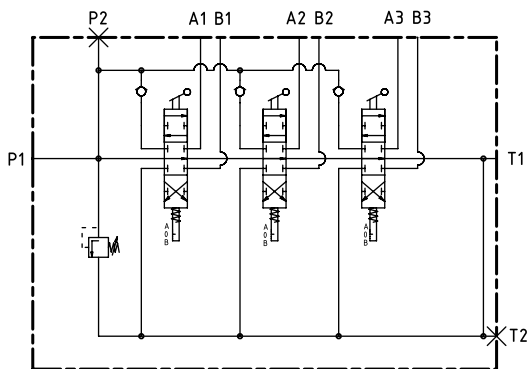

Versione standard distribuzione in parallelo
Standard parallel circuit version

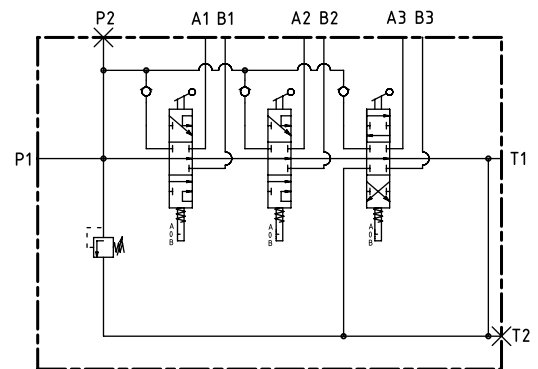

Versione standard distribuzione in serie
Standard series circuit version

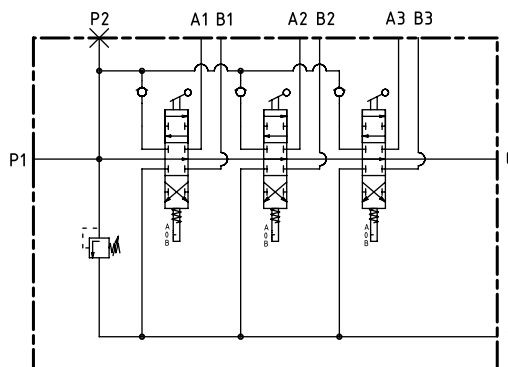

Versione standard elettrico distribuzione in parallelo con CARRY-OVER
Standard electric parallel circuit version with CARRY-OVER

I dati nel presente catalogo non sono impegnativi e possono essere variati senza obbligo di preavviso
Any specification in this catalogue is not binding and can be modified without any notice