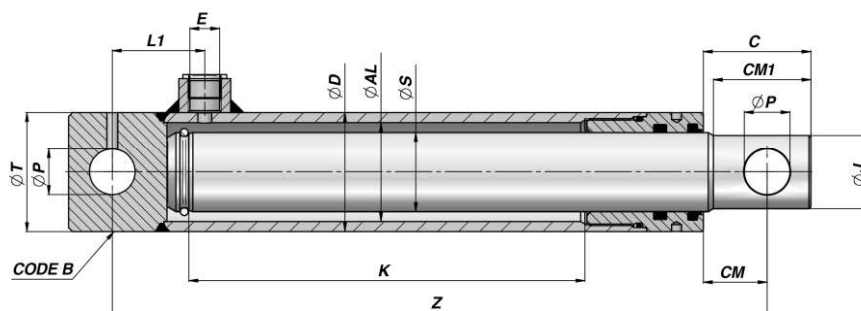

CILINDRO TUFFANTE TIPO "HFRT"
PLUNGER CYLINDER "HFRT" TYPE
HFRT
Series M250

Codice Code	K	Z	kg	E BSP	L1	ØP	CM	C	ØJ	CM1	ØT	Code B
ØD 40 ØAL 30 ØS 25												
HFRT125100	100	190	1,64	3/8"	40	14,10	24	38	22	35	40	CFHR030014030
HFRT125150	150	240	2,05									
HFRT125200	200	290	2,46									
HFRT125250	250	340	2,87									
HFRT125300	300	390	3,28									
ØD 50 ØAL 40 ØS 30												
HFRT230200	200	300	3,64	3/8"	42	16,20	26	42	27	37	50	CFO4005016
HFRT230250	250	350	4,19									
HFRT230300	300	400	4,74									
HFRT230350	350	450	5,30									
HFRT230400	400	500	5,85									
HFRT230550	550	650	7,52									
HFRT230700 NEW!	700	800	9,18									
ØD 60 ØAL 50 ØS 40												
HFRT340200	200	330	6,08	3/8"	47	23,10	32	54	37	49	60	CFHR050023050
HFRT340250	250	380	6,91									
HFRT340300	300	430	7,75									
HFRT340350	350	480	8,58									
HFRT340400	400	530	9,41									
HFRT340550	550	680	11,90									
HFRT340700	700	830	14,40									
ØD 60 ØAL 50 ØS 45												
HFRT345200 NEW!	200	330	6,73	3/8"	47	23,10	34	56	42	49	60	CFHR05023050
HFRT345250 NEW!	250	380	7,69									
HFRT345300 NEW!	300	430	8,66									
HFRT345350 NEW!	350	480	9,62									
HFRT345400 NEW!	400	530	10,58									
ØD 70 ØAL 60 ØS 50												
HFRT450300	300	460	11,40	3/8"	50	25,50	49	74	47	65	65	CFHR07060
HFRT450400	400	560	13,74									
HFRT450550	550	710	17,25									
HFRT450700	700	860	20,77									
ØD 80 ØAL 70 ØS 60												
HFRT560200 NEW!	200	360	12,26	3/8"	50	25,25	36	61	57	57	75	CFHR08070
HFRT560300 NEW!	300	460	15,40									
HFRT560400 NEW!	400	560	18,53									
HFRT560550 NEW!	550	710	23,24									
HFRT560700 NEW!	700	860	27,95									
ØD 92 ØAL 80 ØS 70												
HFRT570300 NEW!	300	509	22,66	3/8"	55	30,25	66	96	67	90	85	CFHR09080
HFRT570400 NEW!	400	609	26,94									
HFRT570500 NEW!	500	709	31,23									

MATERIALE TUBO: ACCIAIO S1 52.3 DIN 2393 ISO H9
TUBE MATERIAL : STEEL S1 52.3 DIN 2393 ISO H9

MATERIALE ASTA: ACCIAIO UNI C45 SAE 1045 CROMO 25 µm ±5 Rating 9 / 200h ISO 10289 - 1999/ISO 9227-NSS
ROD MATERIAL : STEEL UNI C45 SAE 1045 CHROME 25 µm ±5 Rating 9 / 200h ISO 10289 - 1999/ISO 9227-NSS

CARATTERISTICHE TECNICHE : VEDI PAGINA 40 - TECHNICAL SPECIFICATIONS : SEE PAGE 40