

SUBPLATE TYPE ES3B12... AND TYPE ES3C14
GRUNDPLATTE TYP ES3B12... UND TYP ES3C14

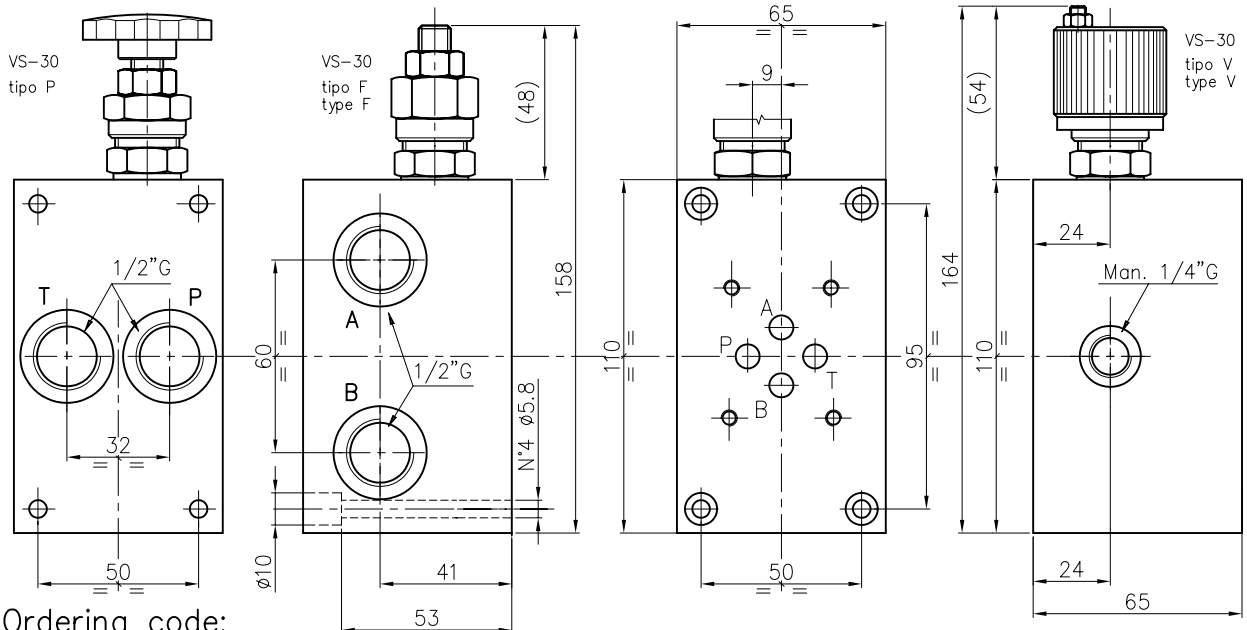

Subplate, A-B side ports 1/2"G, P-T rear ports 1/2"G, with relief valve.(RV) Weight = 3 kg
 Grundplatte, A-B seitlich 1/2"G, P-T rueckseitig 1/2"G, mit Druckbegrenzungsventil.(DBV)
 Gewicht = 3 Kg



Ordering code:
 Bestell-Code:

Subplate
 Grundplatte = S

CETOP 3

Model / Modell = B

1/2"G = 12

Setting / Einstellung: F = by key / Schlussverstellung, V = handwheel/Aluhandrad, P = plastic knob/Kunststoff-handrad

spring type / Feder Typ: 0 = 5-50 bar, 1 = 30-100 bar, 2 = 50-210 bar, 3 = 100-350 bar

X = with RV / mit DBV
 Z = prearranged for RV fuer DBV vorgebohrt

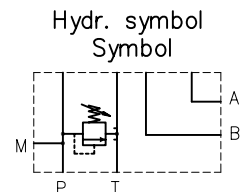

NOTES : See page 50 for technical characteristics of RV
 BEMERKUNG : Siehe techn. Daten des DBV auf Seite 50

Subplate with A-B-P-T back ports, 2 fixing screws. Weight 0.9 kg
 Grundplatte mit A-B-P-T rueckseitigen Anschluessen, 2 Befestigungsbohrungen.
 Gewicht 0.9 Kg

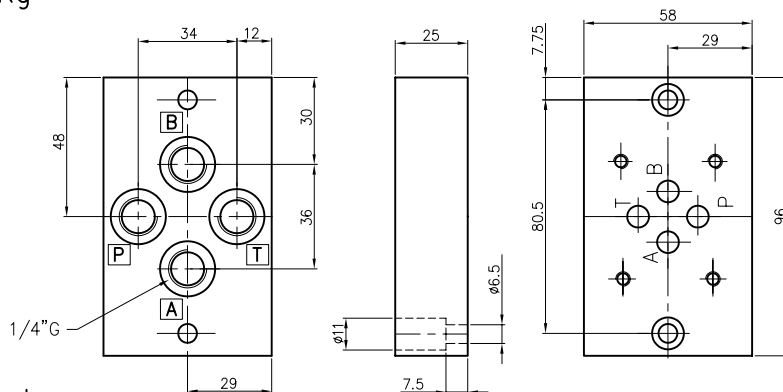

Ordering code:
 Bestell-Code:

Subplate
 Grundplatte = S

CETOP 3

14 = R 1/4"G

C = Model / Modell

