

MONOBLOCK TYPE EMS105/...

MONOBLOCK TYP EMS105/...

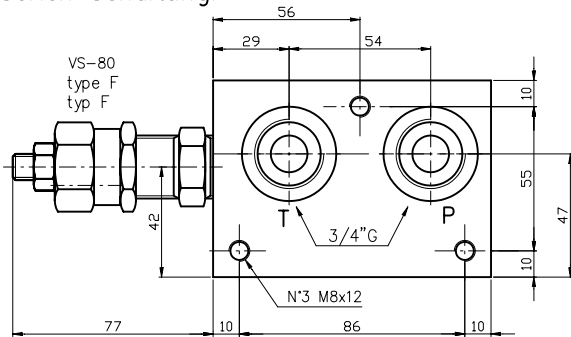

Monoblock with ports A-B on rear, with/without pressure reliefvalve.(RV) Series connection.
 Monoblock mit rückseitigen Anschlüsse A-B, mit/ohne Druckbegrenzungsventil.(DBV)
 Serien Schaltung.



P-B-A-T = 3/4" G

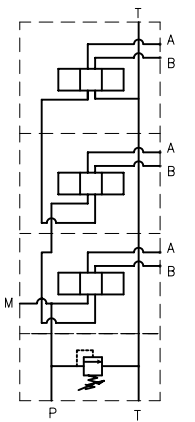
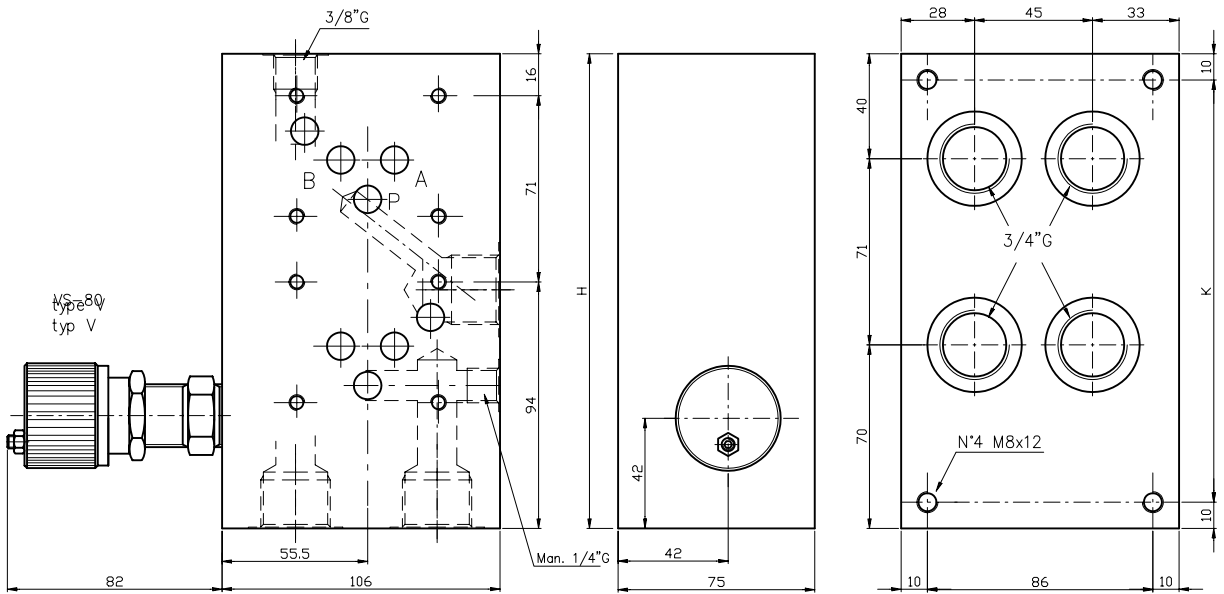

Symbol
 Series conn.
 Serien schalt.

N° Elem.	H	K	Kg
2	181	161	11
3	252	232	15
4	323	303	19

Ordering code
 Bestell-Code:

EM S 10 5 / * * * *

Monoblock = M

series/Serie = S

ports A-B on rear = 10
 rüecks. Anschl A-B

CETOP 5

N. Elem. = 2-3-4
 Anzahl Elemente

Setting/Einstellung
 F = by key/Schlussverstellung
 V = Handwheel/Aluhandrad

Spring type/Feder Typ
 1 = 5-60 bar
 2 = 35-120 bar
 3 = 80-270 bar

Z = prearranged for RV
 mit DBV Bohrung
 T = with plugged RV seat
 mit verstopften DBV Bohrung
 X = with RV included
 einschliesslich DBV

CETOP 5
 NG 10